

APPLICATION:

PRODUCT NAME:

**WALL MOUNTED REEL RINSE  
INSTALLATION KIT**

JOB NAME:

\_\_\_\_\_ SPECIAL CONFIGURATION  
(CHECK BASE MODEL AND OPTIONS)

QUANTITY:

ITEM NO.:

MODEL:

28231

OPTIONS OR MODIFICATIONS:

- SUPPLY LINES (24" OR 36") CIRCLE LENGTH
- HANDLES (CROSS OR WRIST) CIRCLE STYLE
- OTHER \_\_\_\_\_

FEATURES:

- WALL CONTROL VALVE**
- \* ECCENTRICS ADJUST FROM 7-1/2" TO 8-1/2"
  - \* INTERNAL SPRING LOADED CHECK VALVES
  - \* SWIVELING SEAT DISKS
  - \* HOT SIDE STEM - RIGHT HAND
  - \* COLD SIDE STEM - LEFT HAND
  - \* STAINLESS STEEL SEATS
  - \* STAINLESS STEEL SEAT SCREWS
  - \* STAINLESS STEEL HANDLE SCREWS

- RISER CONTROL VALVE**
- \* RIGHT HAND SWIVEL STEM WITH CROSS HANDLE
  - \* STAINLESS STEEL SEAT
  - \* STAINLESS STEEL SEAT SCREW
  - \* STAINLESS STEEL HANDLE SCREW

- VACUUM BREAKER**
- \* ANTI-SPILL DESIGN
  - \* ASSE - 1056 APPROVED

- WALL BRACKET**
- \* ADJUSTS FROM 2" TO 12"

- SYSTEM LIMITS**
- \* TEMP: 40°F TO 140°F MAX.
  - \* PRESSURE 200 PSI MAX. STATIC

- SHIPPING WEIGHT**
- \* 15.0 LBS

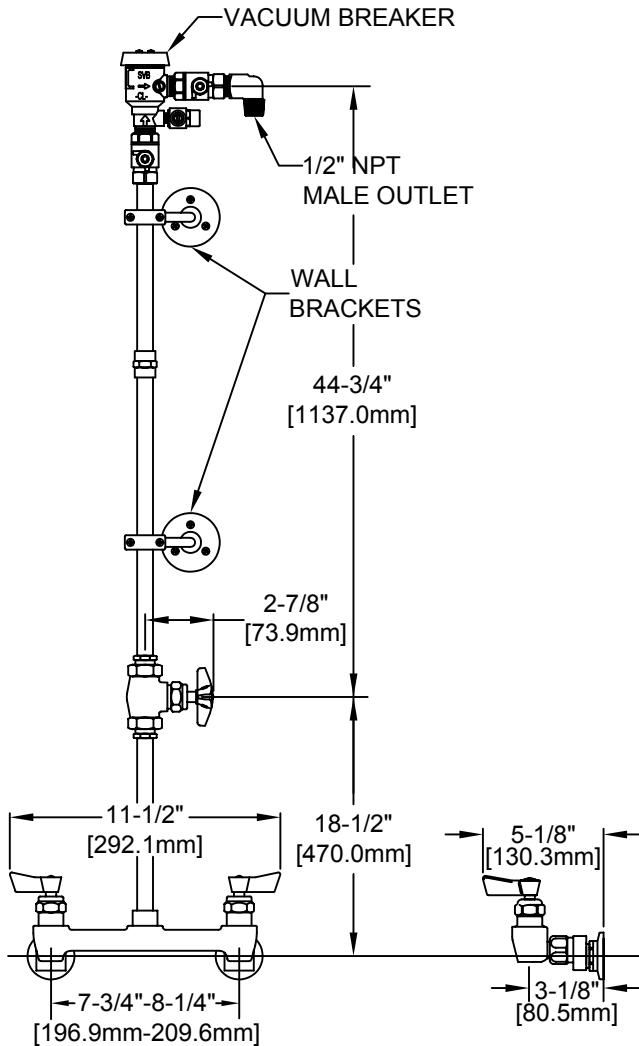

ROUGH-IN:

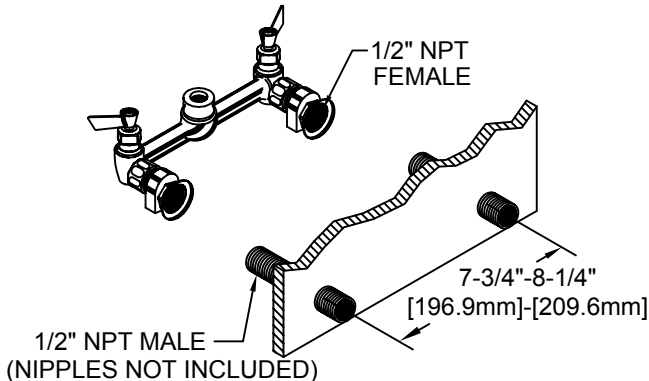

ANSI/A112.18.1M

**FISHER**

FISHER MANUFACTURING COMPANY  
TOLL FREE: 800-421-6162 - FAX: 800-832-8238  
information@fisher-mfg.com - www.fisher-mfg.com